

C92IPBL9-1

Kategori spis	90x60 cm
Antal ugnar med energideklaration	2
Värmekälla, första ugnen	Elektrisk
Typ av häll	Induktion
Huvudugn, typ	Termoventilerad
Typ av extraugn	Statisk
Rengöringssystem huvudugn	Pyrolyt
EAN-kod	8017709268398
Energiklass	A
Energiklass, andra ugnen	A











Estetisk linje

Färg	Svart	Antal vred	8
Estetik	Classic	Färg screentryck	Silver
Serie	Symphony	Ugnshandtag	Smeg Classic
Design	Rak design	Färg på handtag	Borstat rostfritt stål
Lucka	Med 2 horisontella paneler	Typ av ugnsglas	Eclipse
Bakkantslist	Ja	Stödfötter	Silver
Färg på ram runt häll	Rostfritt stål	Ugnsutrymme	Dörr
Ytbehandling kontrollpanel	Emaljerad metall	Logga	Assembled st/steel
Kontrollvred	Smeg Classic	Position logga	Panel under ugnen
Färg på vred	Rostfritt stål	Alternativa färger tillgängliga	Rostfritt stål
Typ av display	Touch		

Program/funktioner

Antal tillagningsfunktioner 9

Traditionella tillagningsfunktioner

 Statisk	 Fläktassisterad	 Varmluft
 Snabb	 Eco	 Liten grill
 Stor grill	 Fläkt + grill (stor)	 Fläktassisterad undervärme

Rengöringsfunktioner

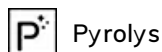

Pyrolysis

Program/funktioner - extraugn

Undervärme + övervärme



Traditionella ugnsfunktioner i ugn 2



Statisk



Liten grill



Stor grill



Undervärme



Fläktassisterad undervärme

Tekniska egenskaper - häll



Totalt antal kokzoner 5

Vänster fram - Induktion Multizon - 2.10 kW - Booster 2.30 kW - 21.0x19.0 cm

Vänster bak - Induktion Multizon - 1.60 kW - Booster 1.85 kW - 22.0x18.5 cm

Mitten - Induktion-enkel - 2.30 kW - Booster 3.00 kW - Ø 27.0 cm

Höger bak - Induktion-enkel - 1.20 kW - Booster 1.40 kW - Ø 18.0 cm

Höger fram - Induktion-enkel - 2.30 kW - Booster 3.00 kW - Ø 21.0 cm

Antal extra snabba kokzoner 5

Ecologic Ja

Multizon Ja

Automatisk avstängning vid överhettning Ja

Automatisk avstängning vid överkokning Ja

Kokkärlsavkänning Ja

Markering för minsta storlek av kokkärl Ja

Indikator för vald zon Ja

Indikationslampa restvärme Ja

Tekniska specifikationer - huvudugn



Antal ljuskällor 1

Antal fläktar 1

Nettovolym 1:a ugn 70 l

Bruttovolym 1:a ugn 79 l

Material ugn Ever Clean emalj

Antal hyllplan 5

Typ av hyllplan Metallstegar

Innertak Ja

Typ av ljuskälla Halogenlampor

Effekt lampa 40 W

Programmering av tillagningstid Start/stopp

Avtagbar innerlucka Ja

Antal glas i ugnsluckan 4

Antal 3

värmereflekterande glas i lucka

Säkerhetstermostat Ja

Värmeelement stängs av vid öppning av ugnsluckan Ja

Kylsystem Tangentialt

Luckan är låst under pyrolytisk rengöring Ja

Nettovolym 360x444x425 mm

Ljuset aktiveras när luckan öppnas	Ja	Inställning av temperatur	Elektromekaniskt
Luckhängning	Underhängd	Effekt undervärme	1200 W
Avtagbar lucka	Ja	Effekt övervärme	1000 W
Innerlucka i helglas	Ja	Grillelement	1700 W
		Värmeelement bred grill - effekt	2700 W
		Effekt varmluftselement	2000 W
		Typ av grill	Elektrisk

Alternativ för huvudugn

Timer	Ja	Min temperatur	50 °C
Koktidslarm	Ja	Max temperatur	280 °C

Tekniska specifikationer - extraugn



Nettovolym 2:a ugn	35 l	Antal glas i ugnslucka	3
Bruttovolym 2:a ugn	36 l	Antal värmereflekterande glas i lucka	1
Material ugn	Ever Clean emalj	Skyddstermostat	Ja
Antal hyllplan	4	Kylsystem	Tangential
Typ av hyllplan	Metallstegar	Nettomått på ugnens insida (hxlxp)	311x206x418 mm
Antal ljuskällor	1	Temperatur	Elektromekaniskt
Typ av ljuskälla	Glödlampa	Undervärme - effekt	750 W
Effekt lampa	25 W	Övervärme - effekt	650 W
Luckhängning	Underhängd	Grillelement	1400 W
Avtagbar lucka	Ja	Stor grill - effekt	2050 W
Innerlucka i helglas	Ja	Typ av grill	Elektrisk
Avtagbar innerlucka	Ja		

Alternativ för extraugn

Minimum temperatur	50 °C	Maximum temperatur	245 °C
--------------------	-------	--------------------	--------

Medföljande tillbehör - huvudugn och häll



Galler med stopp	1	Fullt utdragbara teleskopskenor	1
Ugnsgaller	1	Matlagningstermometer	1
Plåt, 20 mm	2	Barnlås	1
Plåt, 40 mm	1		

Medföljande tillbehör - extraugn

Galler med stopp till ugn	1	Plåt	1
Galler till plåt	1	Barnlås	1

Elektrisk anslutning

Anslutningseffekt	15400 W	Spänning (V)	380-415 V
Ström	43 A	Frekvens	50/60 Hz
Spänning	220-240 V	Typ av kopplingsplint	5 Polig

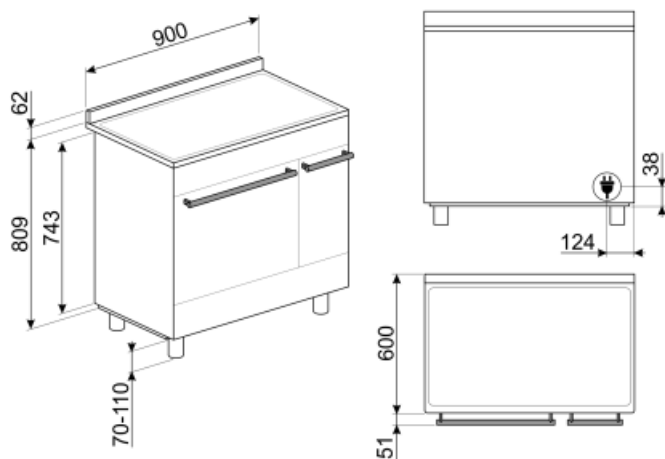

Tillbehör ingår ej



PRTX

Eldfast pizzasten med handtag. D = 35cm Inte lämplig för mikrovågsugnar.



SCRP

Hällskrapa för keramiska hållar

KITPAX

Förhöjningsben (91,4-96,8cm) Rostfritt stål. Passar till Classicspisar



TPKTR9

Teppanyakigrillplatta för Victoria TR9 och Classicspisar med gashäll

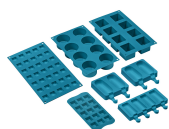

SMOLD

7st silikonformar för glass, isglass, praliner, iskuber, eller matportioner. Klarar temperaturer från -60°C till +230°C

GTT

Totally extractable telescopic guides (1 level) Extraction: 433 mm Material: Stainless steel AISI 430 polished



SFLK1

Luckspärr till inbyggnadsugnar



BGTR9

Cast iron grill plate suitable for 90 cm Victoria, 60 and 90 cm Master and Sinfonia cookers



KITPBX

Sänkningsben (84,5-85,6cm) Passar till Classicspisar

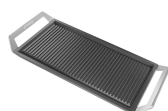

GRIDDLE

Passar både gas och induktion. Non-stickbeläggning

KITC9X9

















Stänkskydd 90x75cm i rostfritt stål.

















GTP

Partially extractable telescopic guides (1 level) Extraction: 300 mm Material: Stainless steel AISI 430 polished



Symbols glossary (TT)

 <p>A: Product drying performance, measured from A+++ to D / G depending on the product family</p>	 <p>Power booster: option allows the zone to work at full power when very intense cooking is necessary.</p>
 <p>Child lock: some models are fitted with a device to lock the programme/cycle so it cannot be accidentally changed.</p>	 <p>Air cooling system: to ensure a safe surface temperatures.</p>
 <p>Triple glazed doors: Number of glazed doors.</p>	 <p>Quadruple glazed: Number of glazed doors.</p>
 <p>Enamel interior: The enamel interior of all Smeg ovens have a special antacid lining which helps keep the interior clean by reducing the amount of cooking grease adhering to it.</p>	 <p>Circogas: In gas ovens the fan distributes the heat quickly and evenly throughout the oven cavity, avoiding flavour transfer when cooking a number of different dishes at the same time. In electric ovens this combination completes cooking more quickly of foods that are ready on the surface, but that require more cooking inside, without further browning.</p>
 <p>Fan with upper and lower elements: The elements combined with the fan aim to provide more uniform heat, a similar method to conventional cooking, so pre-heat is required. Most suitable for items requiring slow cooking methods.</p>	 <p>Upper and lower element only: a traditional cooking method best suited for single items located in the centre of the oven. the top pf the oven will always be hottest. Ideal for roast, fruit cakes, bread etc.</p>
 <p>Upper and lower element only: a traditional cooking method best suited for single items located in the centre of the oven. the top pf the oven will always be hottest. Ideal for roast, fruit cakes, bread etc.</p>	 <p>Lower heating element only: This function is ideal for foods that require extra base temperature without browning, e.g. pastry dishes, pizza. Also suitable for slow cooking of stews and casseroles.</p>
 <p>Circulaire: The combination of the fan and circular element around it gives a hot air cooking method. This provides many benefits including no preheat if cook time is more than 20 minutes, no flavour transfer when cooking different foods at the same time, less energy, and shorter cook times. Good for all types of food.</p>	 <p>ECO: The combination of the grill, fan and lower element is particularly suitable for cooking small quantities of food.</p>
 <p>Grill element: Using of grill gives excellent results when cooking meat of medium and small portions, especially when combined with a rotisserie (where possible). Also ideal for cooking sausages and bacon.</p>	 <p>Half grill: For rapid cooking and browning of foods. Best results can be obtained by using the top shelf for small items, the lower shelves for larger ones, such as chops or sausages. For half grill heat is generated only at the centre of the element, so is ideal for smaller quantities.</p>

- | | |
|--|---|
|  <p>Fan with grill element: The fan reduces the fierce heat from the grill, providing an excellent method of grilling various foods, chops, steaks, sausages etc. giving even browning and heat distribution, without drying out the food. The top two levels recommended for use, and the lower part of the oven can be used to keep items warm at the same time, an excellent facility when cooking a grilled breakfast. Half grill (centre portion only) is ideal for small quantities of food.</p> |  <p>Circulaire with upper and lower elements: The use of the fan with both elements allows food to be cooked quickly and effectively, ideal for large joints that require thorough cooking. It offers a similar result to rotisserie, moving the heat around the food, instead of moving the food itself, enabling any size or shape to be cooked.</p> |
|  <p>Overheat protection: The safety system that automatically turns off the hob in case of overheating of the control unit.</p> |  <p>Induction: The work of these hobs is based on the principle of electromagnetic induction. The heat is generated directly in the bottom of the pan during its contact with the hob.</p> |
|  <p>All glass inner door: All glass inner door, a single flat surface which is simple to keep clean.</p> |  <p>The inner door glass: can be removed with a few quick movements for cleaning.</p> |
|  <p>Side lights: Two opposing side lights increase visibility inside the oven.</p> |  <p>Overfill protection: The special overfill protection shuts down the stove in the presence of overflow of liquids.</p> |
|  <p>Pyrolitic: Pyrolitic cleaning cycles can be selected as necessary to automatically clean the oven interior.</p> |  <p>Indication of residual heat: After the glass ceramic hob is switched off the residual heat indicator shows which of the heating zones still remains hot. When the temperature drops below 60 ° C, the indicator goes out.</p> |
|  <p>Removable roof liner: This is a perfect solution that protects the upper part of the cavity of the oven from pollution. Easy to remove for cleaning, it can be washed in the dishwasher.</p> |  <p>The oven cavity has 4 different cooking levels.</p> |
|  <p>The oven cavity has 5 different cooking levels.</p> |  <p>Telescopic rails: allow you to pull out the dish and check it without having to remove it from the oven entirely.</p> |
|  <p>Electronic control: Allows you to maintain temperature inside the oven with the precision 2-3 ° C. This enables to cook meals that are very sensitive to temperature changes, such as cakes, souffles, puddings.</p> |  <p>The capacity indicates the amount of usable space in the oven cavity in litres.</p> |
|  <p>The capacity indicates the amount of usable space in the oven cavity in litres.</p> | |