

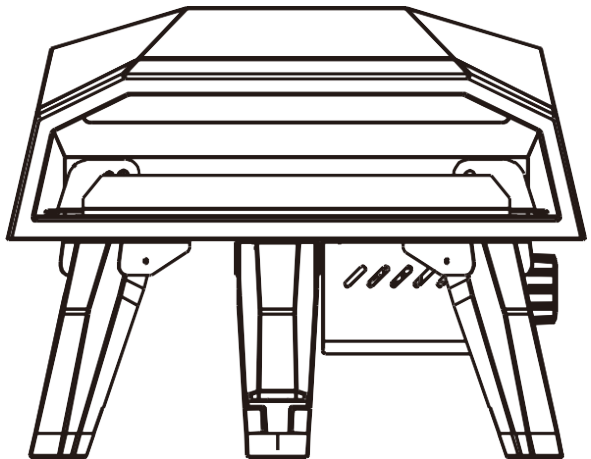

Cooler

MANUAL & SAFETY INSTRUCTIONS



<p>Do not store spare LP-gas cylinder under or near the appliance. Never fill the cylinder beyond 80 percent full.</p> <p>If the information beyond is not followed exactly, a fire causing death or serious injury may occur.</p> <p>Minimal clearance from sides and back of the unit to combustible construction, 36 inches from the sides and 36 inches from the front.</p> <p>Not to use the appliance under overhead combustible surfaces.</p> <p>CAUTION: Use only the gas pressure regulator supplied with this appliance. This regulator is set for an outlet pressure of 11 lwc.</p> <p>Turn off the LP supply al cylinder when appliance is not in use. This appliance is not intended for commercial use.</p>	<p>LIGHTING INSTRUCTION - TO LIGHT THE BURNER</p> <ul style="list-style-type: none"> • Make sure the control knob is in OFF position, and then turn the liquid propane cylinder valve ON by slowly turning counterclockwise . • Push in and slowly turn the control knob anticlockwise until you hear a click and the burner ignites. • If burner doesn't light, turn the knob OFF, wait 5 minutes and repeat the lighting.
--	--

	LP	Rate Input (BTU/H)
Components	Orifice Size	
Main Burner	1.20mm	15000

	Modet: P200		 PIN: EN
Category	<input type="checkbox"/> 13+(28-30/37)	<input type="checkbox"/> 13B/P(30)	<input type="checkbox"/> 13B/P(S0)
Type of gas	Butane	Propane	Butane, propane or their mixture
Gas pressure	28-30 mbar	37 mbar	28-30 mbar 50 mbar
Total heat input	4.4 kW		
Appliance type	A1		
Injector size/markings	1.08mm	1.08mm	0.94mm
Destination countries	BE, CH, CY, C2, ES, FR, GB, GR, IE, IT, LT, LU, LV, PT, SK, SI	AL, CY, DK, EE, FI, HU, IT, LT, NL, NO, SE, SI, SK, RO, HR, TR, BG, IS, LU, MT, LV	AT, CH, DE, SK
This appliance shall be installed in conformity with the current regulations and used only in a well-ventilated location. Consult the instructions before installing and using this appliance.			



WARNINGS

& WARNING

To reduce the risk of fire, burn hazard or other injury, read this safety manual carefully and completely before using this appliance.

& WARNING

Before cleaning, make sure the gas supply and control knob is in the OFF position and that the burner and oven has cooled.

& WARNING

Never operate this appliance unattended. If a fire should occur, keep away from the appliance and immediately call your fire department. Do not attempt to extinguish an oil or a grease fire with water.

Failure to follow these instructions could result in fire, explosion or burn hazard which could cause property damage, personal injury or death.

& WARNING

FOR OUTDOOR USE ONLY.

& DANGER

If you smell gas:

- Shut off gas to the appliance
 - Extinguish any open flame
- If odour continues, keep away from the appliance and immediately call your gas supplier or your fire department.

& WARNING

- Keep the fuel supply hose away from any heated surface(s).
- The use of alcohol, prescription or non-prescription drugs may impair the consumer's ability to properly assemble or safely operate the appliance.
- Keep children and pets away from the appliance at all times.
- Do not move the appliance when in use.
- This appliance is not intended for and should never be used as a heater.

& WARNING

Spiders and insects can nest inside the burner of the appliance and disrupt gas flow. Inspect the burner at least once a year.

& WARNING

When using a match to light the appliance, make sure to use the included matchstick holder.

& WARNING

Do not store this appliance indoors unless the gas cylinder is disconnected.

& WARNING

Do not store gas cylinder in a building, garage or any other enclosed area and keep out of reach of children at all times.

& WARNING

This appliance is not intended to be installed in or on recreational vehicles and/or boats.

&

WARNING

Check all gas supply fittings for leaks before each use. Do not use the appliance until all connections have been checked and do not leak.

& WARNING

Do not smoke while leak testing. Never leak test with an open flame.

& WARNING

When lighting, keep your face and hands as far away from the appliance as possible.

& WARNING

Minimum clearance from sides of unit to combustible construction is 610mm (24 inches).



- The parts which have been sealed by the manufacturer should not be adjusted by the user
- When the appliance is using LPG A LPG cylinders should be used
The LPG cylinder size: max diameter-350mm, max height-400mm.
- The appliance is to be installed with sufficient ventilation to prevent the occurrence of unacceptable concentrations of substances harmful to health in the room in which the appliance is installed
- The minimum distances between the appliance and adjacent walls is 0.5m
- The hose for the appliance should not exceed 1.5m
- The appliance should be installed in a suitably ventilated room. Permanent supply of fresh air is ensured and there is no accumulation of unburned gases
- The gas supply tubing or hose shall comply with the national requirements in force and shall be periodically examined and replaced as necessary.
- The hose should comply with the standard EN16436. The regulator should comply with the standard EN16129.
The hose and regulator assembly may not be provided with the appliance in some regions.
- Check and suitably clean the inside of the oven before it is lit in order to avoid the emission of fire from the oils that have accumulated during previous cooking.
- The burner outlets should be checked for obstruction during previous cooking.
The burner outlets should be checked for obstruction and cleaned regularly with a soft wire brush.
- It is necessary to avoid obstruction and to allow for a good combustion
The position of the connection flexible tube so as to ensure that it is not subjected to twisting.

BEFORE LIGHTING

Inspect the gas supply hose prior to turning on the gas. If there is evidence of cut, wear or abrasion, it must be replaced prior to use. Screw the regulator onto the gas cylinder. Leak check the hose and regulator connections with a soap and water solution before lighting the appliance.

LP GAS CYLINDER WARNING

- Do not store spare liquid propane gas cylinder under or near this appliance.
- Never fill the cylinder beyond 80 percent capacity.
- Liquid propane cylinder must be fitted with an OVERFILL PROTECTION DEVICE (OPD).
- If the information above is not followed exactly, a fire resulting in death or serious injury may occur.

SAFETY PRACTICES TO AVOID INJURY

When properly cared for, your oven will provide safe, reliable service for many years. However, extreme care must be used as the oven produces intense heat that can increase the risk of accidents.

When using this oven basic practices must be followed, including but not limited to following:

- Do not repair or replace any part of the oven unless specifically recommended in this manual. All other service should be referred to a qualified technician.
- Children should not be left alone or unattended in an area where the oven is being used. Do not allow children to sit, stand or play around the oven at any time.
- Never let clothing or other flammables come in contact with or too close to any burner or hot surface until it has cooled. The fabric could ignite, causing serious personal injury.
- For personal safety, wear proper apparel. Loose fitting garments or sleeves should never be worn while using the oven. Some synthetic fabrics are highly flammable and should not be worn while cooking.
- Do not heat unopened food containers as a buildup of pressure may cause the containers to burst. When lighting the burner, always pay close attention to what you are doing.
- When using the oven, do not touch the outer shell, stone baking board or immediate surroundings as these areas become extremely hot and could cause burns.
- Do not use the oven to cook extremely fatty meats or other products which increase flare-up.
- Keep the area surrounding the oven free from combustible material including fluids, trash and vapours such as gasoline or charcoal lighter fluid.
- Do not obstruct the flow of combustion and ventilation air.
Never use the oven in extremely windy conditions.
- The temperature under the oven is high. Do not place the oven on a table with flammable table cloths, plastic or any other inflammable materials.

PARTS LIST

- PIZZA Oven
- Stone baking board

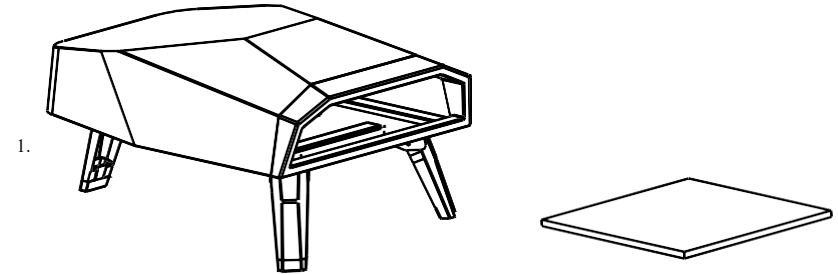

ASSEMBLY

Before assembly, make sure all parts are present. If any part is missing or damaged, do not attempt to assemble the appliance. Contact customer service for replacement parts.

- Unfold legs

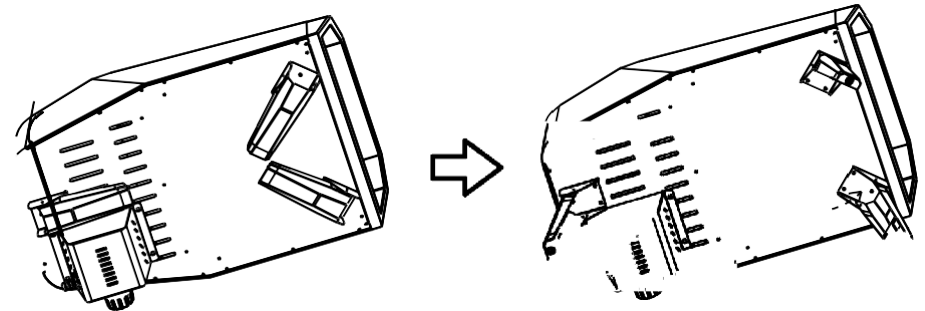

- Insert the stone baking board

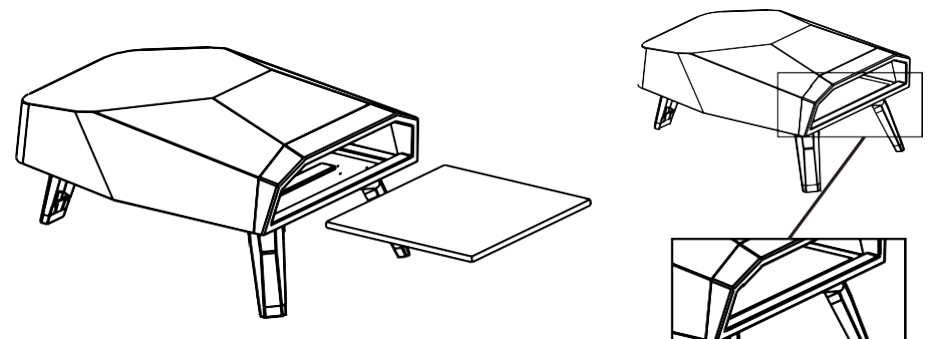

3. Connecting gas hose to P200

Depending on your region the hose may be preassembled.

3a. Connecting gas hose directly to P200

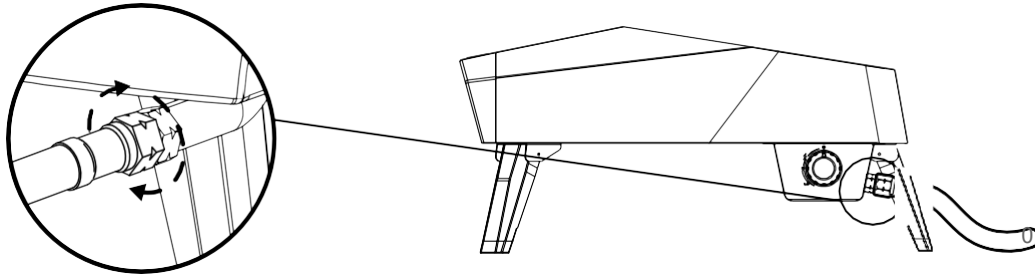

3b i). Connecting barb to

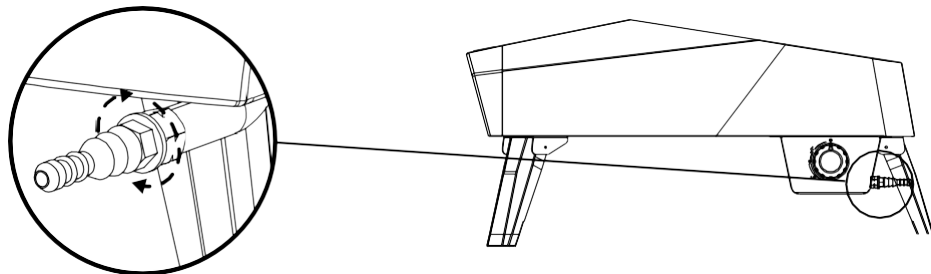

3b ii). Connecting gas hose to barb

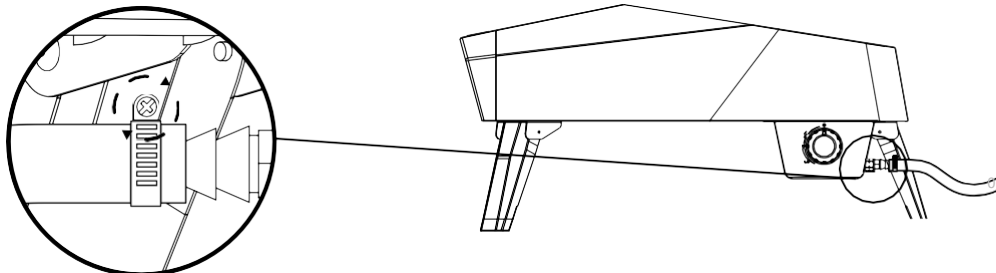

4. Connecting to gas tank

& WARNING

Please always keep the gas bottle in upright position.

- The size for 20 lbs LP gas cylinder is 12.2 inches in diameter and 17.9 inches tall. If the appliance is not in use, the gas must be turned off at the supply cylinder.
- The cylinder used must include a collar to protect the cylinder valve. The minimum distance for the appliance and the 20lb gas tank is 40 inches apart.

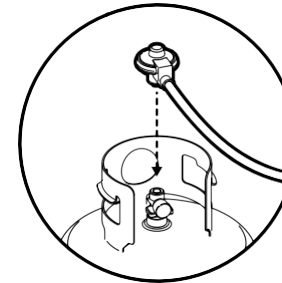

PATIO GAS REGULATOR

This is a push-on gas fitting. Ensure that the black switch is in the horizontal position. Depress the button located below the black switch and press the regulator on to the tank valve until it locks into place.

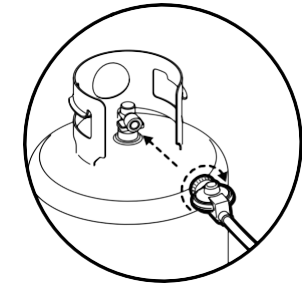

POL GAS REGULATOR

This gas fitting is counterclockwise. Make sure that the tank is completely switched off and screw the regulator as far as possible into the gas tank valve.

CONNECTING THE LIQUID PROPANE GAS CYLINDER

1. To connect the liquid propane gas cylinder:
2. The cylinder valve should be in **OFF** position.
3. Make sure the burner valve is in **OFF** position.
4. Inspect the valve connections, port and regulator assembly. Remove debris and inspect the hose for damage.
5. When connecting the regulator assembly to the valve, use your hand to tighten the nut clockwise until it stops. Use of a wrench could damage the quick coupling nut and result in a hazardous situation.
6. Open the cylinder valve fully by turning the valve counterclockwise.
7. Before lighting the oven, use a soap and water solution to check all connections for leaks.
8. If a leak is found, turn the cylinder valve **OFF**, and do not use the oven until local liquid propane dealer can make repairs.

CONNECTING THE LIQUID PROPANE GAS CYLINDER

1. Turn the oven burner valve **OFF** and make sure the oven is cool.
2. Turn the liquid propane cylinder valve **OFF** by turning clockwise until it stops.
3. Detach the regulator assembly from the cylinder valve by turning the quick coupling nut counterclockwise.
4. Place dust cap for cylinder valve outlet whenever the cylinder is not in use.

LEAK TESTING

GENERAL

Although the gas connections of the appliance are leak tested prior packing and shipment, a complete test must be performed at the installation site.

Before each use, check all the gas connections for leak testing using the procedure listed below. If the smell of gas is detected at any time, you should immediately stop using and check the entire system for leaks.

BEFORE TESTING

Make sure all packing material has been removed from the appliance.

Make a solution of one part liquid detergent and one part water. You will need a spray bottle, brush or rag to apply the solution to the fittings.

TO TEST

1. Turn the burner valve **OFF**
2. Turn the liquid propane cylinder valve on counterclockwise to open the valve.
3. Apply the soap solution to all gas fittings. Soap bubbles would appear where a leak is present.
4. If a leak is present, immediately turn the gas supply **OFF** and tighten leaky fittings.
5. Turn the gas back **ON** and recheck.
6. Should the gas continue to leak from any of the fittings, turn the gas supply **OFF** and contact customer service.

OPERATING INSTRUCTIONS

USING THE OVEN

Each burner is rated at 4.0KW. To begin:

1. Make sure the oven has been leak tested and properly placed.
2. Remove any remaining packing material.
3. Light the burner using the LIGHTING INSTRUCTIONS below

LIGHTING INSTRUCTION

TO LIGHT THE BURNER

1. Make sure the control knob is in OFF position, and then turn the liquid propane cylinder valve ON by slowly turning counterclockwise.
2. Push in and slowly turn the control knob anticlockwise until you hear a click and the burner ignites.
3. If burner doesn't light, turn the knob OFF, wait 5 minutes and repeat the lighting.

TO LIGHT WITH A MATCH

1. If burner will not light after several attempts using the control knob, the burner may be lit with a match.
2. If you have already attempted to light the burner using the control knob, wait 5 minutes for any gas to dissipate. Insert a match into the matchstick holder, ignite the match and insert through the oven opening to the burner.
4. Push and turn the control knob to HI slowly, the burner should ignite immediately.
5. If the burner does not light within seconds, turn the control knob OFF and wait 5 minutes and try again.

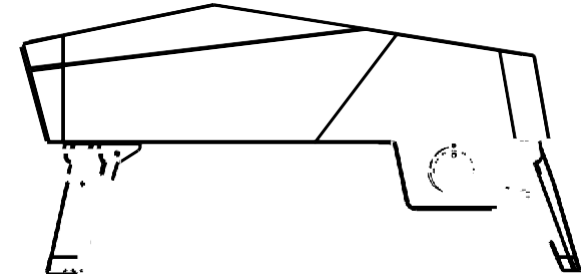
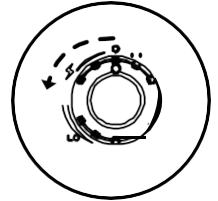

CARE AND MAINTENANCE

Store NL-P200 out of direct sunlight and indoors where possible and when storing for extended periods of time. NL-P200 should not be exposed to harsh weather conditions such as snow, heavy rain and strong winds.

Wait for NL-P200 to cool completely before removing.

The outer shell of NL-P200 may fade over time and through use. This will not affect performance.

STONE BAKING BOARD

1. DO NOT use the stone over an open flame
2. Avoid extreme temperature change to the stone. DO NOT place frozen foods on a hot stone
3. The stone is fragile and can break if bumped or dropped
4. The stone is very hot during use and stays hot for a long time after use.
5. DO NOT cool the stone with water when the stone is hot
6. After cleaning the stone with water, please dry the stone before use. This can be done in a conventional oven at 60°C (140° F) for 2 hours.

TROUBLESHOOTING

Problem	Possible Cause	Prevention/Solution
Burner will not light	<ol style="list-style-type: none"> 1. No gas flow 2. Coupling nut and regulator not fully connected 3. Obstruction of gas flow 4. Disengagement of burner to valve 5. Incorrect assembly 	<ol style="list-style-type: none"> 1. Check to see if propane tank is empty 2. Turn the coupling nut about one-half to three quarters additional turn until solid stop. Tighten by hand only - do not use tools 3. Clear burner tube 4. Reengage burner and valve 5. Check steps in assembly instructions
Sudden drop in gas flow or low flame	<ol style="list-style-type: none"> 1. Out of gas 	<ol style="list-style-type: none"> 1. Check for gas in propane tank 2. Turn off gas control knob, wait 30 seconds and light oven. If flames are still low, turn off gas control knob and propane tank valve. Disconnect regulator. Reconnect regulator and leak test. Turn on propane tank valve, wait 30 seconds and then light oven.
Flames blow out	<ol style="list-style-type: none"> 1. High or gusting winds 2. Low on propane gas 	<ol style="list-style-type: none"> 1. Turn front of oven away from wind 2. Refill propane tank 3. Refer to Sudden drop in gas flow above
Flare-up	<ol style="list-style-type: none"> 1. Grease build up 2. Excessive fat in meat 3. Excessive cooking temperature 4. Excess flour on the cooking surface 	<ol style="list-style-type: none"> 1. Clean oven 2. Trim fats from meat before cooking 3. Adjust (lower) temperature accordingly 4. Brush remnant flour from cooking surface 5. Flip stone
Flashback (fire in burner tube, roaring sound from burner)	<ol style="list-style-type: none"> 1. Burner and/or burner tubes are blocked 2. Pressure drop during ignition 	<ol style="list-style-type: none"> 1. Turn gas control knob off. Clean burner and/or burner tubes. 2. Turn off oven, ensure the tank valve is fully open (if applicable) and relight.