

KitchenAid

Coffee Maker 5KCM1208



EN	Use & Care manual	2	NO	Håndbok for bruk og vedlikehold	135
DE	Gebrauchs- und Pflegeanleitung	17	FI	Käyttö- ja huolto-opas	149
FR	Manuel d'utilisation et d'entretien	33	DA	Vejledning til anvendelse og vedligehold	163
IT	Manuale d'uso e manutenzione	51	IS	Notenda & Meðhöndlunar handbók	177
NL	Gebruiks- en onderhoudshandleiding	65	RU	Руководство по эксплуатации и уходу	191
ES	Manual de uso y cuidado	79	PL	Instrukcja obsługi i konserwacji	205
PT	Manual de utilização e manutenção	93	CS	Návod k použití a údržbě	219
EL	Εγχειρίδιο Χρήσης και Φροντίδας	107	TR	Kullanım ve Bakım kılavuzu	233
SV	Handbok för skötsel och användning	121	AR	دليل الاستخدام والعناية	1

PARTS AND FEATURES

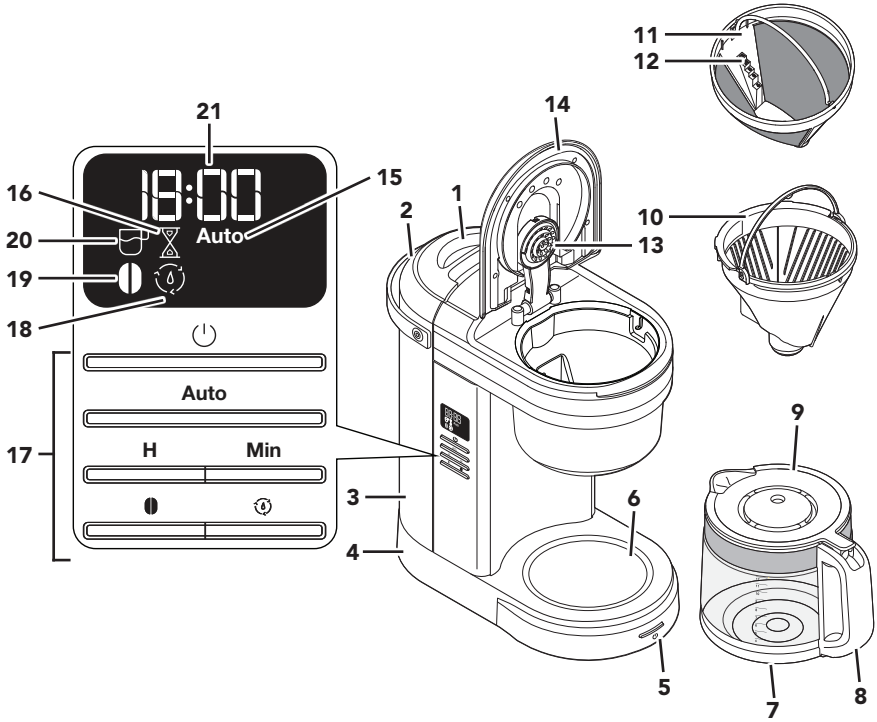

- | | | | |
|----|----------------------------------|----|-------------------------------|
| 1 | Water Tank Lid | 12 | Dosage Ladder |
| 2 | Water Tank Handle | 13 | Showerhead |
| 3 | Water Tank | 14 | Brew Basket Lid |
| 4 | Cord Storage in Base (not shown) | 15 | Auto Icon |
| 5 | Brew/Cancel Button | 16 | Remaining Keep Warm Time Icon |
| 6 | Warming Plate | 17 | Control Panel |
| 7 | Glass Carafe | 18 | Clean Icon |
| 8 | Carafe Handle | 19 | Bold Icon |
| 9 | Carafe Lid | 20 | Brew Icon |
| 10 | Brew Basket | 21 | Clock |
| 11 | Gold Tone Filter | | |

NOTE: Default measurement for 1 cup = approximately 147 ml.

PRODUCT SAFETY

Your safety and the safety of others are very important.

We have provided many important safety messages in this manual and on your appliance. Always read and obey all safety messages.



This is the safety alert symbol.

This symbol alerts you to potential hazards that can kill or hurt you and others.

All safety messages will follow the safety alert symbol and either the word “DANGER” or “WARNING.” These words mean:

 **DANGER**

You can be killed or seriously injured if you don't immediately follow instructions.

 **WARNING**

You can be killed or seriously injured if you don't follow instructions.

All safety messages will tell you what the potential hazard is, tell you how to reduce the chance of injury, and tell you what can happen if the instructions are not followed.

IMPORTANT SAFEGUARDS

When using electrical appliances, basic safety precautions should always be followed, including the following:

1. Read all instructions. Misuse of appliance may result in personal injury.
2. European Union only: Appliances can be used by persons with reduced physical, sensory or mental capabilities or lack of experience and knowledge if they have been given supervision or instruction concerning use of the appliance in a safe way and understand the hazards involved. Children shall not play with the appliance.
3. European Union only: This appliance shall not be used by children. Keep the appliance and its cord out of reach of children.
4. Do not touch hot surfaces. Use handles or knobs.
5. Do not operate any appliance with a damaged cord or plug, or after the appliance malfunctions, or is dropped or damaged in any manner. Return appliance to the nearest Authorised Service Facility for examination, repair, or electrical or mechanical adjustment.
6. To protect against fire, electric shock and injury to persons do not immerse appliance in water or other liquid.
7. Unplug from outlet when not in use and before cleaning. Allow to cool before putting on or taking off parts, and before cleaning the appliance.
8. Close supervision is necessary when any appliance is used by or near children.
9. Do not let cord hang over the edge of table or counter or touch hot surfaces.
10. This appliance is not intended for use by persons (including children) with reduced physical, sensory or mental capabilities, or lack of experience and knowledge, unless they have been given supervision or instruction concerning use of the appliance by a person responsible for their safety.

PRODUCT SAFETY

11. Children should be supervised to ensure that they do not play with the appliance.
12. Turn the appliance OFF, then unplug from the outlet when not in use, before assembling or disassembling parts and before cleaning. To unplug, grasp the plug and pull from the outlet. Never pull from the power cord.
13. Do not place on or near a hot gas or electric burner, or in a heated oven.
14. The use of attachments not recommended or sold by KitchenAid may cause fire, electrical shock, or injury.
15. Do not use the appliance outdoors.
16. Do not use appliance for other than intended use.
17. Do not let cord hang over edge of table, or counter.
18. Never leave the appliance unattended while it is in operation.
19. Do not use appliance without lid properly placed on Carafe.
20. The Carafe is designed for use with this appliance. It must never be used on a range top or in a microwave oven.
21. Do not set a hot Carafe on a wet or cold surface.
22. To disconnect, press the  button, then remove plug from wall outlet.
23. Scalding may occur if the lid is removed during the brewing cycles.
24. Do not use a cracked Carafe or a Carafe having a loose or weakened handle.
25. Do not clean Carafe with abrasive cleaners, steel wool pads, or other abrasive material.
26. Do not fill the Water Tank above the marked maximum fill line.
27. Do not overfill Glass Carafe. If the Glass Carafe is overfilled, brewed coffee may be ejected.
28. This appliance is intended to be used in household and similar applications such as:
 - staff kitchen areas in shops, farmhouses, offices, or other working environments;
 - farmhouses;
 - by clients in hotels, motels and other residential type environments;
 - bed and breakfast type environments.
29. Refer to the “Care and Cleaning” section for instructions on cleaning the surfaces in contact with food.
30. If the supply cord is damaged, it must be replaced by the manufacturer, its service agent or similarly qualified persons in order to avoid a hazard.
31. The heating element surface is subject to residual heat after use. Do not touch hot surface. Use handles.
32. Coffee Maker shall not be placed in cabinet when in use.

SAVE THESE INSTRUCTIONS

Instructions are also available online, visit our website at:
www.KitchenAid.co.uk or www.KitchenAid.eu

PRODUCT SAFETY

ELECTRICAL REQUIREMENTS

⚠ WARNING



Electrical Shock Hazard

Plug into an earthed outlet.

Do not remove earth prong.

Do not use an adapter.

Do not use an extension cord.

Failure to follow these instructions can result in death, fire, or electrical shock.

Voltage: 220-240 Volts AC

Frequency: 50-60 Hz

Wattage: 1100 W

NOTE: If the plug does not fit in the outlet, contact a qualified electrician. Do not modify the plug in any way. Do not use an adapter.

Do not use an extension cord. If the power supply cord is too short, have a qualified electrician or service technician to install an outlet near the appliance.

The cord should be arranged so that it will not drape over the countertop or tabletop where it can be pulled on by children or tripped over unintentionally.

ELECTRICAL EQUIPMENT WASTE DISPOSAL

Disposal of packing material

The packing material is recyclable and is marked with the recycle symbol . The various parts of the packing must therefore be disposed of responsibly and in full compliance with local authority regulations governing waste disposal.

Scrapping the product

- This appliance is marked in compliance with European Directive 2012/19/EU, Waste Electrical and Electronic Equipment (WEEE).

- By ensuring this product is disposed of correctly, you will help prevent potential negative consequences for the environment and human health, which could otherwise be caused by

inappropriate waste handling of this product.



- The symbol  on the product or on the accompanying documentation indicates that it should not be treated as domestic waste but must be taken to an appropriate collection centre for the recycling of electrical and electronic equipment.

For more detailed information about treatment, recovery and recycling of this product, please contact your local city office, your household waste disposal service, or the shop where you purchased the product.

DECLARATION OF CONFORMITY

This appliance has been designed, constructed and distributed in compliance with the safety requirements of EC Directives: 2014/35/EU, 2014/30/EU, 2009/125/EC and 2011/65/EU (RoHS Directive).

GETTING STARTED

SETTING THE CLOCK

⚠ WARNING



Electrical Shock Hazard

Plug into an earthed outlet.

Do not remove earth prong.

Do not use an adapter.

Do not use an extension cord.

Failure to follow these instructions can result in death, fire, or electrical shock.

NOTE: When the Coffee Maker is first plugged in or when power is restored after an interruption, the display will initially show 12:00.

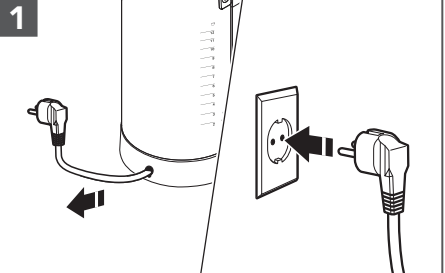

Cord is stored in the base. If needed, gently pull cord outwards. Plug into an earthed outlet.

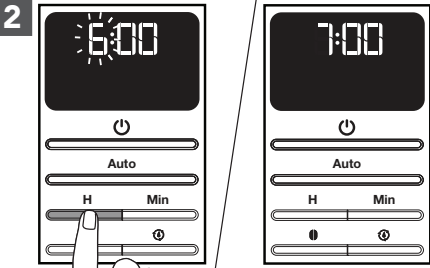

Press **H** to set the hour. The hour digits will change with each press; or press and hold to scroll rapidly.

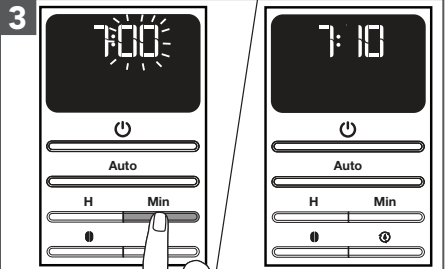

Press **Min** to set the minutes.

To save the current displayed time and exit clock set-up: Press any other button or do not press any button for 10 seconds.

PRODUCT USAGE

SETTING THE BREW STRENGTH

1

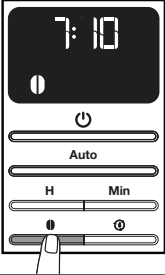

To switch between Regular and Bold brew strengths: Press  button.

NOTE: Regular is the default setting.

TIP: While brewing small batches (2-4 cups), using the “Bold Setting” is recommended.

FILLING WATER FOR BREWING

TIP: Brew 2 Carafe of fresh, cool water and discard before brewing the first Carafe of coffee.

1

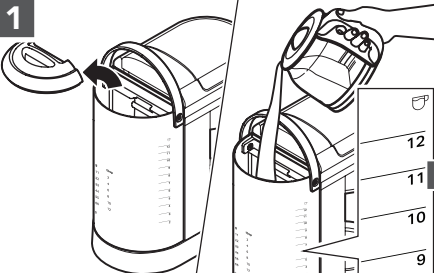

Pour fresh water in the Water Tank. Use the level markings. Then, close the lid properly.

1

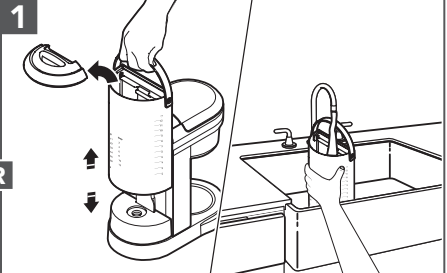

Lift the Water Tank up gently. Pour fresh water in the Water Tank. Place the Water Tank back in position properly.

NOTE: Fill the Water Tank with only the amount of water needed to brew your desired number of cups. If you put in 12 cups of water, the Coffee Maker will brew all 12 cups.

2

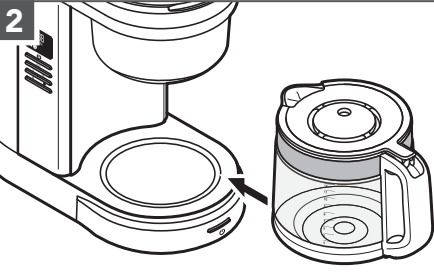

Place the Carafe in the Coffee Maker. Make sure the Carafe lid is in place and bottom of the Carafe is fully seated.

PRODUCT USAGE

ASSEMBLY OF BREW BASKET

1

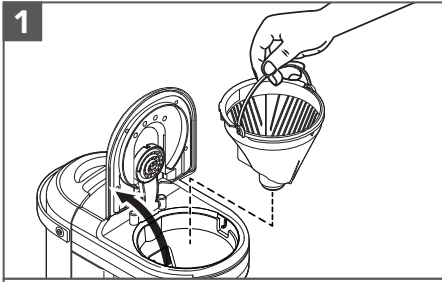

Raise the Brew Basket Lid and remove the Brew Basket.

2

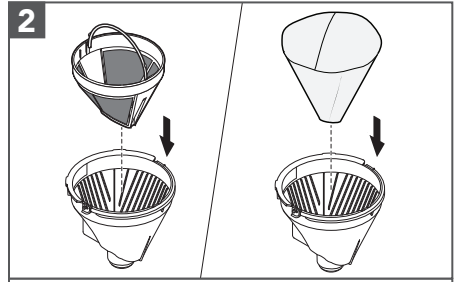

Insert the Gold Tone permanent filter or cone paper filter into the Brew Basket.

TIP: The coffee filter can also be inserted and coffee grounds added with or without removing the Brew Basket from the Coffee Maker.

3

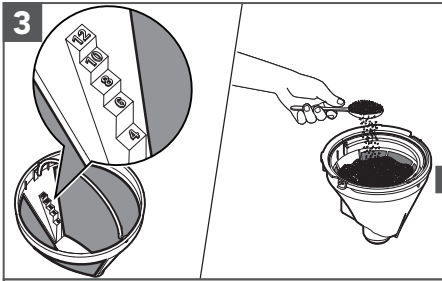

Gold tone permanent filter: Add coffee grounds. Use the "Dosage Ladder".
For example: If you need 8 cups of Brew Coffee, then add coffee grounds till 8 cups scale level.

3

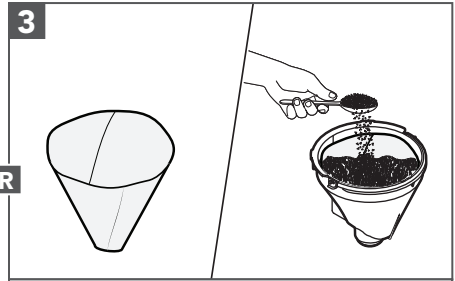

Cone paper coffee filter: Add desired coffee grounds. Use the "coffee dosage chart" on the back of the Water Tank as a guide for how much coffee grounds to use. Pre-wetting the paper is not required.

IMPORTANT: Do not use both types of filters at the same time. Using both filters might cause water and coffee to overflow the Brew Basket.

4

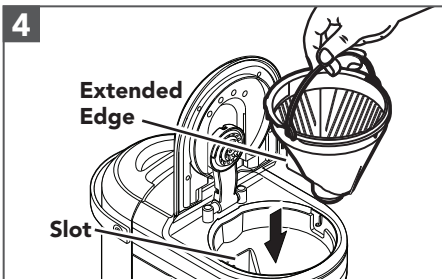

Place the basket into the Coffee Maker aligning with the slot.

5

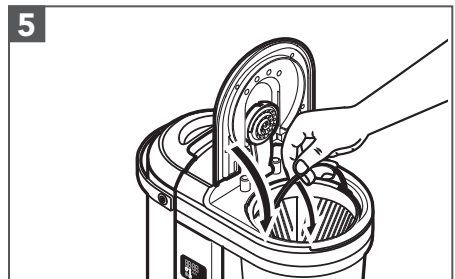

Be sure the Brew Basket Lid is fully closed before brewing.

PRODUCT USAGE

PROGRAMMING THE AUTO SET FEATURE

IMPORTANT: Set the correct time as per the instructions in "Setting the clock" before using the Auto Set feature.

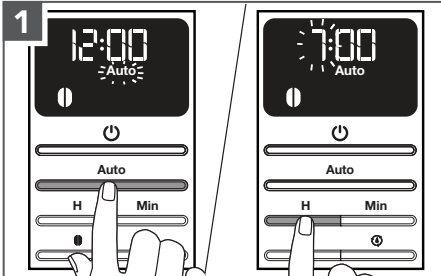

Press the **Auto** button one time. The Auto indicator light will flash and the time display will change to the currently set Auto Set time (12:00 is the default time).

To set the time the Coffee Maker should begin brewing: Press the **H** button to set hour. The hour digits will change with each press; or press and hold to scroll rapidly.

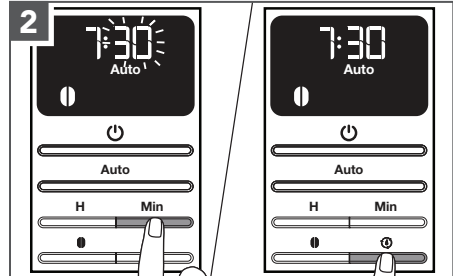

Next, press the **Min** button to set minute. The hour setting will stay solid and the minute setting will begin to blink.

To save the Auto set time and exit set-up: Press any other button or do not press any button for 10 seconds. The Auto indicator will remain lit and the time display will go back to the current time.

TIP: To cancel the Auto Set time after programming is complete: Press **Auto** button again; or press the  button.

NOTE: Default standard brewing cycle time for a full Carafe (12 cups) is approximately 10-minutes.

USING THE PREVIOUSLY PROGRAMMED AUTO SET TIME

These steps can be followed to save the Auto Set time after following the steps in the "Programming the Auto Set feature" section.

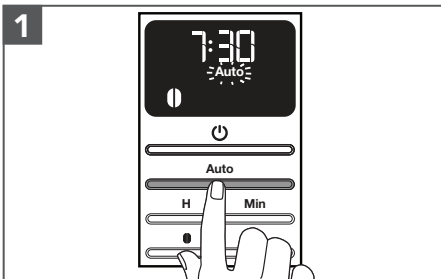

Press the **Auto** button. The Auto indicator will flash and the time display will show the previously set Auto time.

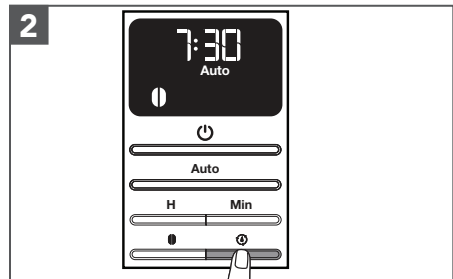

To save the current displayed time and exit set-up: Wait for 10 seconds, or press any button. The Auto indicator will remain lit and the time display will go back to the current time.

BREWING COFFEE

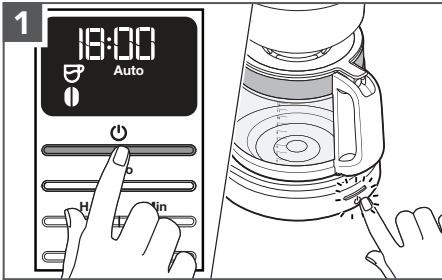

Press any of the  buttons provided on side or on front to begin brewing coffee.

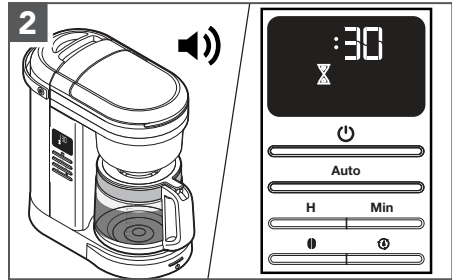

The Coffee Maker will beep 3 times when the Brew cycle is complete. Then, 30 minutes Warm mode will start.

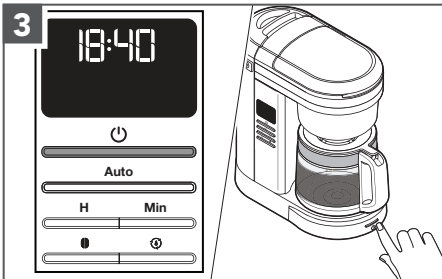

After Warm mode end, the Coffee Maker will automatically turn off. To Cancel Brew cycle or Warm mode, press the  button once.

TIP: Opening the Brew Basket while coffee is brewing will interrupt the brew process and impair the flavour.

IMPORTANT: Allow the Coffee Maker to cool for 5 minutes before starting next brew cycle.

PAUSE AND POUR FEATURE

The "Pause and pour" feature enables you to remove the Carafe and pour a cup of coffee before brewing is finished. When the Carafe is removed, a special valve stops the flow of coffee from the Brew Basket. However, brewing does not stop.

Make sure to place the Carafe back in the place within 25 seconds to avoid the overflow of the water and coffee grounds from the Brew Basket.

CARE AND CLEANING

NOTE: Unplug and allow the Coffee Maker to cool down before cleaning.

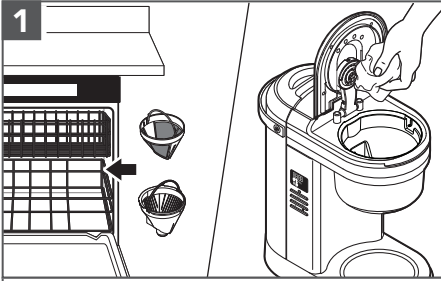

Dishwasher-safe parts, top rack only: Brew Basket and Gold Tone Permanent filter. Wipe the Showerhead with a damp cloth to remove any coffee splashes.

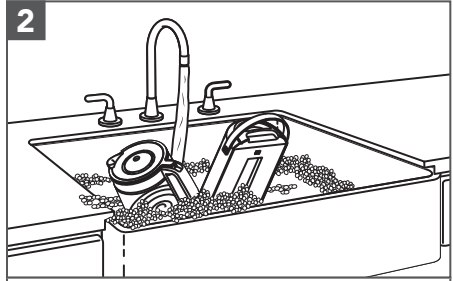

Wash by hand in warm and soapy water. Dry thoroughly: Carafe and Water Tank.

REMOVING MINERAL DEPOSITS WITH VINEGAR

Mineral deposits (scale) from water will build up in the Coffee Maker over the time and impair brewing efficiency and coffee quality. The "Clean icon (☼)" will flash in display after completing 100 brew cycles. Then, it is time to descale the Coffee Maker.

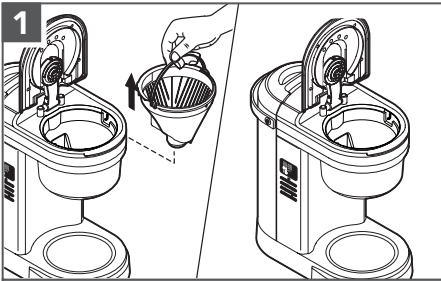

Empty the Brew Basket.

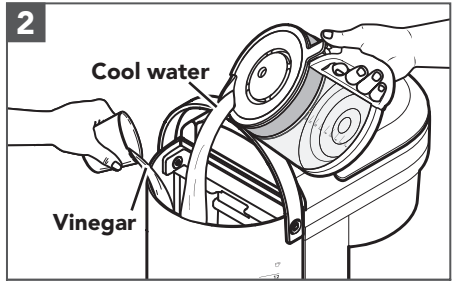

Fill the Water Tank with 1.4 L (6 cup) vinegar and 1.4 L (6 cup) cool water.

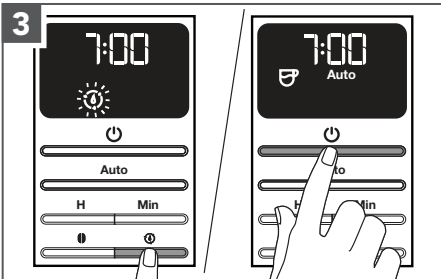

Press ☼ button. Then, press any of the ⏻ buttons to begin the Clean cycle. After the Clean cycle ends (approximately 30 minutes), 3 beeps will sound, and the "Clean icon (☼)" will turn off.

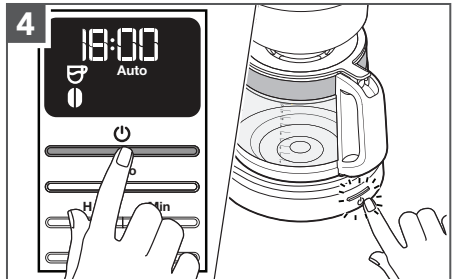

Run 2-3 fresh, cool water-only cycles after the Clean cycle is complete.

TROUBLESHOOTING GUIDE



⚠ WARNING

Electrical Shock Hazard

Plug into an earthed outlet.

Do not remove an earth prong.

Do not use an adapter.

Do not use an extension cord.

Failure to follow these instructions can result in death, fire, or electrical shock.

Problem	Solution
If the display is not illuminated:	Check if the Coffee Maker is plugged into an earthed outlet. If it is, check the fuse or circuit breaker on the electrical circuit the Coffee Maker is connected to and make sure the circuit is closed.
If only a portion of the water added to the Coffee Maker actually brews:	The Coffee Maker requires immediate descaling. Please refer to the "Care and Cleaning" section.
Coffee Maker takes longer than usual to brew:	
If you hear 3 rapid tones:	There is no water in the Water Tank. See the "Filling Water for Brewing" section.
If "Er1" flashes on the display and you hear 1 tone:	A button may be jammed. Unplug and press each button several times. Plug the Coffee Maker. If "Er1" appears again on the display, repeat this procedure.
If coffee overflows the Brew Basket:	<p>The Brew Basket is not correctly in place. See the "Assembly Of Brew Basket" section.</p> <p>Too much coffee ground was placed into the Brew Basket.</p> <p>Used both Gold tone filter and paper filter together.</p>
If water exits from the back of the Coffee Maker:	Too much water was poured into the Water Tank.

If the problem is not due to one of the above items, see the "Terms of KitchenAid Guarantee ("Guarantee")" section. Do not return the Coffee Maker to the retailer. Retailers do not provide service.

TERMS OF KITCHENAID GUARANTEE ("GUARANTEE")

Covering U.K. - Ireland - South Africa - UAE

KitchenAid Europa, Inc., Nijverheidslaan 3, Box 5, 1853 Strombeek-Bever, Belgium ("**Guarantor**") grants the end-customer, who is a consumer, a Guarantee pursuant to the following terms.

FOR U.K.:

The Guarantee applies in addition to and does not limit or affect the statutory warranty rights of the end-customer against the seller of the product. In summary, the Consumer Rights Act 2015 says products must be as described, fit for purpose and of satisfactory quality. During the expected lifespan of your product your legal rights entitle you to the following:

- Up to 30 days: if your product is faulty, then you can get an immediate refund.
- Up to six months: if your product can't be repaired or replaced, then you're entitled to a full refund, in most cases.
- Up to six years: if your product does not last a reasonable length of time you may be entitled to some money back.

These rights are subject to certain exceptions. For detailed information please visit the Citizens Advice website www.adviceguide.org.uk or call **03454 04 05 06**.

FOR IRELAND:

The Guarantee applies in addition to and does not limit or affect the statutory warranty rights of the end-customer against the seller of the product under the European Communities (Certain Aspects of the Sale of Consumer Goods and Associated Guarantees Regulations 2003 (S.I. No. 11/2003)) and other enactments governing the sale of consumer goods.

FOR SOUTH AFRICA:

The Guarantee applies in addition to and does not limit or affect the statutory warranty rights of the end-customer against the seller of the product. In summary, the Consumer Protection Act, 2008 says that products must be: (i) reasonably suitable for the purpose for which they are intended; (ii) in good working order, of good quality and free of any defects; (iii) useable and durable for a reasonable period of time, having regard to the use to which they would normally be put and to all the surrounding circumstances; and (iv) in compliance with any applicable standards or any other public regulations.

During the expected lifespan of your product and where the products are not purchased online, your legal rights will entitle you to the following:

- You will be entitled to a full refund, if you did not have the opportunity to examine the product before delivery and if you rejected delivery of the product on the basis that the type and quality of the product was not as reasonably expected or did not reasonably conform to the material specifications.
- Within 5 business days after delivery: you may rescind your purchase and request a refund, if your purchase resulted from direct marketing.
- Within 10 business days after delivery: you will be entitled to a full refund, if it is found that the product was unsuitable for a particular purpose specifically communicated to you by the Guarantor.
- Within 15 business days after delivery: you will be entitled to a refund if: (i) the product was not delivered to you; or (ii) if you returned the product to the Guarantor.
- Within 6 months after delivery: you will be entitled to a refund or a replacement product, if the product is defective or fails to operate in terms of its specifications.

TERMS OF KITCHENAID GUARANTEE ("GUARANTEE")

Where you have purchased a product online your legal rights will be governed by the Electronic Communications and Transactions Act, 2002 and you will be entitled to the following:

- Within 7 days after conclusion of the transaction or after delivery: you may cancel your purchase without reason and without penalty.
- Within 30 days of the date of cancellation of the transaction: you will be entitled to receive a refund, if you have already made payment.
- You will only be liable for the direct costs of returning the product to the Guarantor.

FOR UAE:

The Guarantee applies in addition to and does not limit or affect the statutory warranty rights of the end-customer against the seller of the product.

1) SCOPE AND TERMS OF THE GUARANTEE

a) The Guarantor grants the Guarantee for the products mentioned under Section 1.b) which a consumer has purchased from a seller or a company of the KitchenAid-Group within the following countries: U.K., Ireland, or South Africa, or the United Arab Emirates (UAE).

b) The Guarantee period depends on the purchased product and is as follows:

5KCM1208 Two years full guarantee from date of purchase.

c) The Guarantee period commences on the date of purchase, i.e. the date on which a consumer purchased the product from a dealer or a company of the KitchenAid-Group.

d) The Guarantee covers the defect-free nature of the product.

e) The Guarantor shall provide the consumer with the following services under this Guarantee, at the choice of the Guarantor, if a defect occurs during the Guarantee period:

- Repair of the defective product or product part, or
- Replacement of the defective product or product part. If a product is no longer available, the Guarantor is entitled to exchange the product for a product of equal or higher value.

f) If the consumer wishes to make a claim under the Guarantee, the consumer has to contact the country specific KitchenAid service centres or the Guarantor directly at KitchenAid Europa, Inc. Nijverheidslaan 3, Box 5, 1853 Strombeek-Bever, Belgium;

Email-Address U.K.: CONSUMERCARE.UK@kitchenaid.eu

Email-Address IRELAND: CONSUMERCARE.IE@kitchenaid.eu

Toll Free Number U.K. & IRELAND: **00 800 381 040 26**

FOR SOUTH-AFRICA:

Our local KitchenAid Distributor:

KitchenAid Africa
PO Box 52102
V&A Waterfront
Cape Town
8002

TERMS OF KITCHENAID GUARANTEE ("GUARANTEE")

Contact our distributor:

Telephone: +27 21 555 0700

You can contact our Customer Service Centre for Small Domestic Appliances from 8.30 am to 1.00pm and from 1.30 pm to 5.00 pm or write to us at the following address: hello@kitchenaidafrica.com

FOR UAE:

AL GHANDI ELECTRONICS.

POST BOX NO. 9098,

DUBAI, UNITED ARAB EMIRATES

Toll free number: +971 4 2570007

g) The costs of repair, including spare parts, and any postage costs (if applicable) for the delivery of a defect-free product or product part shall be borne by the Guarantor. The Guarantor shall also bear the postage costs for returning the defective product or product part if the Guarantor or the country specific KitchenAid customer service centre requested the return of the defective product or product part. However, the consumer shall bear the costs of appropriate packaging for the return of the defective product or product part.

h) To be able to make a claim under the Guarantee, the consumer must present the receipt or invoice of the purchase of the product.

2) LIMITATIONS OF THE GUARANTEE

a) **The Guarantee applies only to products used for private purposes and not for professional or commercial purposes.**

b) **The Guarantee does not apply in the case of normal wear and tear, improper or abusive use, failure to follow the instructions for use, use of the product at the wrong electrical voltage, installation and operation in violation of the applicable electrical regulations, and use of force (e.g. blows).**

c) **The Guarantee does not apply if the product has been modified or converted, e.g. conversions from 120 V products to 220-240 V products.**

d) **The provision of Guarantee services does not extend the Guarantee period, nor does it initiate the commencement of a new Guarantee period. The Guarantee period for installed spare parts ends with the Guarantee period for the entire product.**

e) FOR SOUTH-AFRICA & UAE ONLY:

Further or other claims, in particular claims for damages, are excluded unless liability is mandatory by law.

After expiry of the Guarantee period or for products for which the Guarantee does not apply, the KitchenAid customer service centres are still available to the end-customer for questions and information.

Further information is also available on our website:

- For U.K. & Ireland www.kitchenaid.eu
- For South-Africa: www.kitchenaidafrica.com
- For UAE: www.KitchenAid-MEA.com

PRODUCT REGISTRATION

Register your new KitchenAid appliance now: <http://www.kitchenaid.eu/register>

