

With Elvita, you make room for all the things you appreciate. You get carefully selected products with smart solutions for a good price, designed to make life easy.



Small design



Reversible doors



Easy to use

CKF2146V Combined fridge freezer

- 492 mm height
- 472 mm width
- 43 litre capacity
- Reversible doors
- Energy class E

Designed for compact living, built for everyday use

This fridge freezer is a great choice for any home that needs a compact appliance for a smaller kitchen. With adjustable feet, it stands securely on any surface. At just 492 mm in height and with a 43-litre capacity, it's ideal for smaller households that need dependable storage without taking up too much room. Perfect for those who need efficient cooling in a compact, space-saving design.

Reversible doors

With a compact kitchen, space can be a problem. However, with the reversible doors and adjustable height, you can customise this fridge freezer to fit perfectly in your cosy kitchen.

Easy to adjust the temperature

Easily change the temperature manually in both the fridge and freezer at the same time by using the temperature selector knob. This convenient fridge freezer is a truly reliable friend in every kitchen.

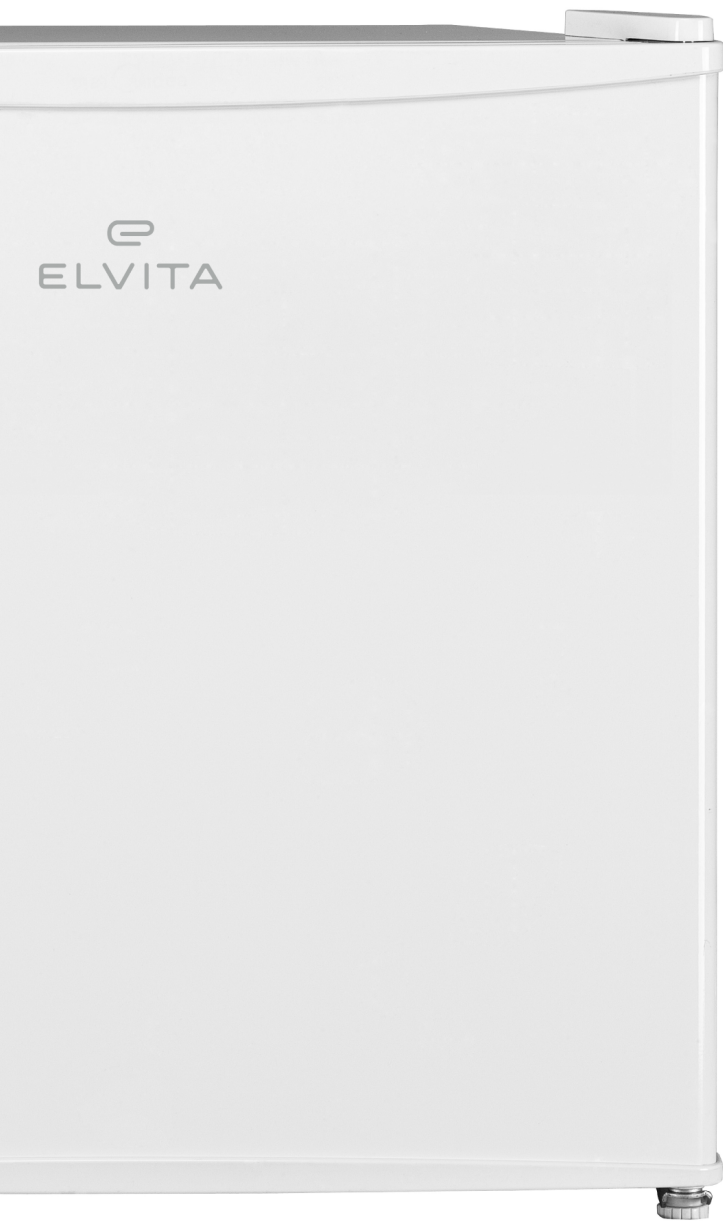

Product properties

Colour	White
Installation	Freestanding
Auto defrost	No
Display	No
Super freeze	No
Door alarm	No
LED lights	No
Door hinges	Reversible
Refrigerator volume	43 l
Bottle rack	Yes
Adjustable bottom feet	Front

Technical specifications

Net weight	13.6 kg
Gross weight	14.6 kg
Height	492 mm
Width	472 mm
Depth	450 mm
Number of compressors	1
Total volume	43 l
Energy consumption	80 kWh/year
Power supply	220~240 V / 50 Hz
Cord length	1.7 m
Rated current	0.4 A
Airborne acoustical noise emission	41 dBA
Airborne acoustical noise emission class	C
Climate class	N/ST
Energy efficiency class	E
Model identifier	CKF2146V

For details about the energy efficiency of the product, go to <https://eprel.ec.europa.eu/>. Use the model identifier to find information.

Dimensions

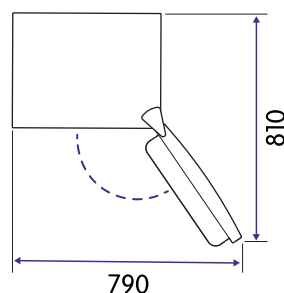
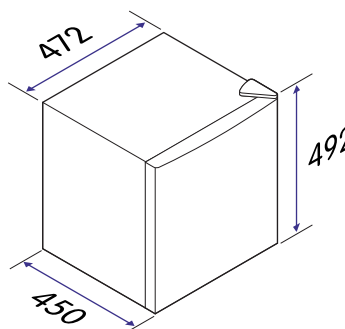

(mm)

The information may be subject to changes. Inadvertent errors in information may occur.

Energy label

