

With Elvita, you make room for all the things you appreciate. You get carefully selected products with smart solutions for a good price, designed to make life easy.



Reversible doors



Adjustable feet



LED light



Door alarm

## CKF1175X Combined fridge freezer

- 595 mm width
- 1736 mm height
- 209 litre refrigerator capacity
- 113 litre freezer capacity
- Rear feet adjustable from the front

### The fridge freezer for every home

Enjoy spacious capacity and multiple storage options in this combined fridge freezer. With functional design and reversible door this fridge freezer will be a perfect match to any kitchen.

### Varied and adjustable storage options

This fridge freezer has storage options for all types of food. Whether it be keeping fruits and vegetables fresh or frozen food nutritious and tasty for a very long time in the four-star compartments, this product can do it. Both the fridge and freezer have lots of space and the glass shelves can be moved to make room for all needs.

### User- and environmental-friendly

Let the fridge freezer do the job. The fridge freezer runs quietly and is energy efficient both for you and the environment. To help you find your favourite foods, this product uses a LED light that is brighter, more durable, and more energy efficient than a standard bulb.

### Easy to adjust the temperature

Easily change the temperature manually in both the fridge and freezer at the same time by using the temperature selector knob. This convenient fridge freezer is a truly reliable friend in every kitchen.

### Adjustable feet

The adjustable rear feet provide an easy way to stabilise and level the product. With features that allow front access to the rear feet, the installation process is quick and efficient.



## Product properties

Colour	Stainless steel
Installation	Freestanding
Auto defrost	No
Display	No
Super freeze	No
Door alarm	Yes
LED lights	Yes
Door hinges	Reversible
Refrigerator volume	209 l
Freezer volume	113 l
Bottle rack	No
Adjustable bottom feet	Yes

## Technical specifications

Net weight	68 kg
Gross weight	71.2 kg
Height	1736 mm
Width	595 mm
Depth	677 mm
Food safe during power outage	13 hours
Number of compressors	1
Total volume	322 l
Energy consumption	238 kWh/year
Power supply	220~240 V / 50 Hz
Cord length	2.4 m
Rated current	0.7 A
Airborne acoustical noise emission	38 dBA, rel 1pW
Airborne acoustical noise emission class	C
Climate class	SN, N, ST
Energy efficiency class	E
Model identifier	CKF1175X

For details about the energy efficiency of the product, go to <https://eprel.ec.europa.eu/>. Use the model identifier to find information.

## Dimensions

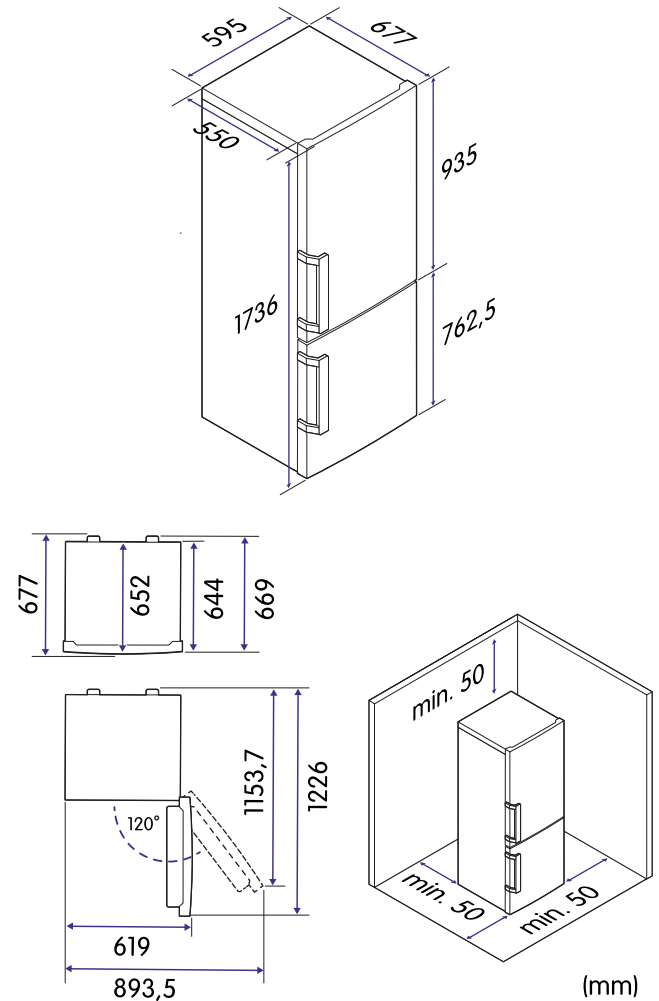

The information may be subject to changes. Inadvertent errors in information may occur.

## Energy label

